

SPECIFICATION GUIDE

Rockfon® System Mono® Acoustic



Sounds Beautiful

Contents

General	2	Installation	10
Product	3	Installation overview – FE	10
The panel	3	Installation overview – TE	11
The grid	3	Planning	12
Why Rockfon Mono Acoustic?	4	Consumption guide	13
Portfolio	5	Checklist	14
The Colours of Wellbeing	5	Air pressure	15
Sustainability	5	Diffuse ventilation	16
Performance	6	Temperature	17
Quality and service	7	Humid environments	18
Certified Installer Network	7	Restrictions	19
Training facilities	8	Technical drawings	20
On-site support	8		
Maintenance	9		

General

What is the purpose of this document?

The purpose of this Specification guide is to provide relevant technical information during the design- and specification process. It's useful for work planners, specifiers, architects, designers, installers and more.

This guide covers topics such as product & portfolio information, installation overview, jobsite planning, technical details and maintenance (aftercare).

Product

The panel

Rockfon Mono Acoustic is a multi-layered product, comprising of high-quality components to achieve best in class results.

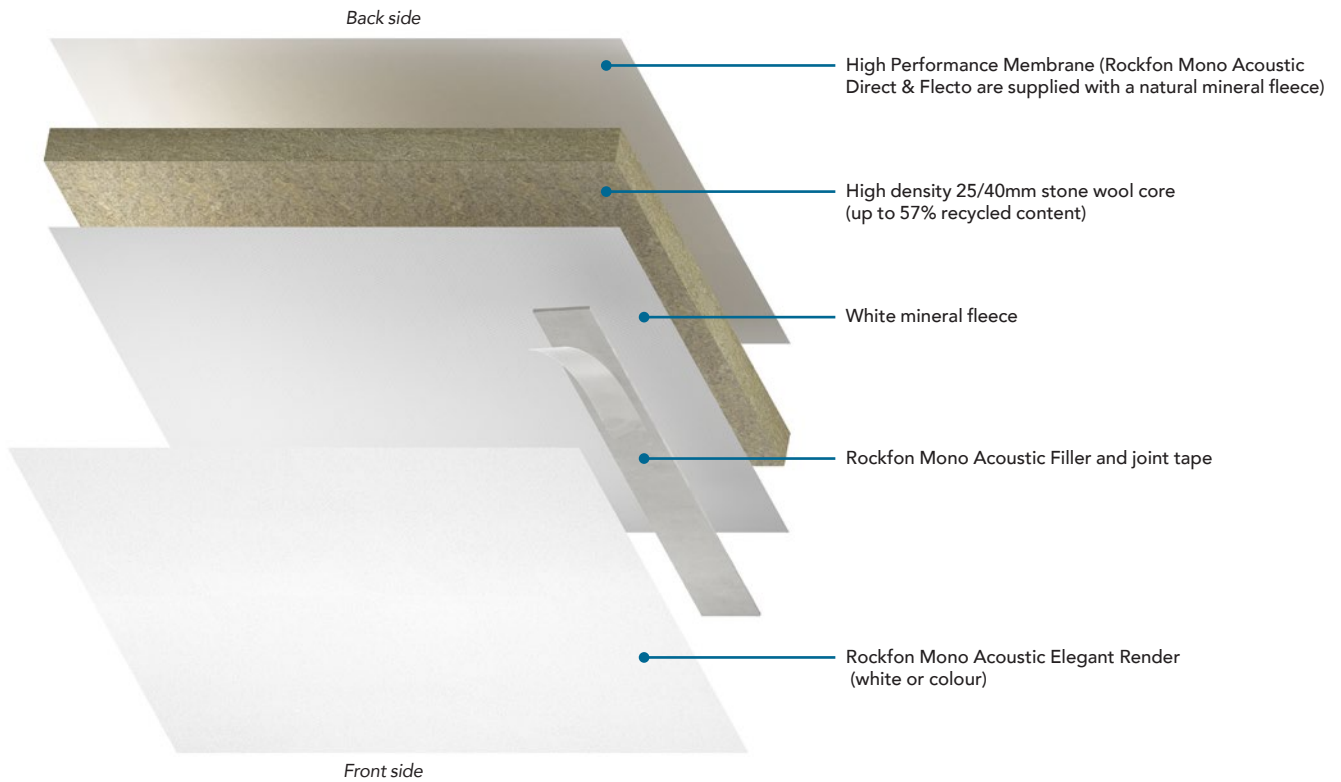

Please have a look at our technical datasheet or get in touch with our local customer service for more specific information.

The grid

The Rockfon Mono Acoustic panel is installed on a grid specifically designed for this system, called Chicago Metallic™ Monolithic.

The grid consists of a main runner, a cross furring channel and a C channel for the perimeter. It's a quick and easy to install single layer click system that is suspended with rigid hangers.



Chicago Metallic™ Monolithic main runner T35.



Chicago Metallic™ Monolithic cross furring channel.



Chicago Metallic™ Monolithic C Channel trim.

Why Rockfon Mono Acoustic?

Rockfon Mono Acoustic is a unique monolithic surface solution to achieve signature designs. Design freeform shapes for walls and ceilings suitable for many project types and sizes. Above all, Mono is a best in class sound absorber and enables you to design for optimal well-being.

Product benefits

- A seamless and flexible acoustic solution with complete design freedom.
- The monolithic surface is easy to maintain and refresh, making it a sustainable choice for the future.
- The white surface provides even light distribution, reducing the need for artificial light.
- Available in custom colours or select from our curated palette of 33 Colours of Wellbeing.
- Available in a suspended and direct mounted version, flat or curved, in thicknesses 25 and 40 mm to suit almost every situation.
- Best in class (tested and certified) product properties such as Class A sound absorption, reaction to fire Class A (white) and the full product Cradle to Cradle Silver certified.
- Rockfon Mono Acoustic is fully recyclable.
- Unique possibility to offer diffuse ventilation through the monolithic surface, eliminating the need of visible ventilation units.
- All relevant environmental labels are available and easily accessible online, including Environmental Product Declarations that declare the assessed life cycle environmental impact of our product.
- The quality of the end result is assured due to an intensively trained, certified and up-to-date installer network.
- Numerous reference projects to back up our promise.



Portfolio

Rockfon Mono Acoustic is available in various product variants:

Rockfon Mono Acoustic

Rockfon Mono Acoustic is designed for installation on the Chicago Metallic™ Monolithic grid (suspended mounting). Rockfon Mono Acoustic has a High Performance Membrane on the back side.

Rockfon Mono Acoustic Direct

Rockfon Mono Acoustic Direct is meant only for installation directly against an airtight substrate (e.g. concrete or plasterboard).

Rockfon Mono Acoustic Flecto

Rockfon Mono Acoustic Flecto is designed for curved applications and can, similar to Rockfon Mono Acoustic Direct, only be applied directly against an airtight substrate (e.g. bendable plasterboard).

All products are available in dimensions ranging from 900 x 1200 mm up to 1800 x 1200 mm. Available thicknesses are 25 and 40 mm.

The Colours of Wellbeing

Experience unlimited design freedom with Rockfon Mono Acoustic. Choose your own custom colour or select from our Colours of Wellbeing palette, expertly curated to evoke feelings of calm and well-being.



Support Sustainability

Sustainability sits at the heart of our research and development. It's why we use natural stone, constantly reduce our carbon footprint, and recycle to look after our planet and our people.

Rockfon Mono Acoustic is Cradle to Cradle Certified® Silver and has all necessary documentation to support you earn points in building certifications, such as BREEAM, DNGB, LEED, and WELL.



Performance



Sound absorption

α_w : up to 1,00 (Class A)

* Rockfon Mono Acoustic panels

** Rockfon Mono Acoustic Direct panels

Sound absorption values are valid for flat surfaces.

When conducting an acoustic study, please take into account the services integrated into the ceiling as well as the project layout.

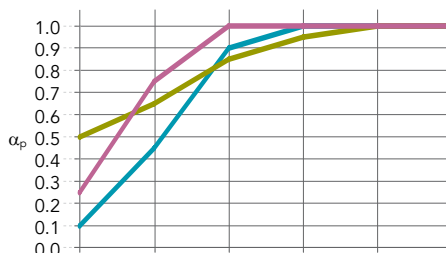

Thickness (mm) / Suspension (incl. tile - mm)

	125 Hz	250 Hz	500 Hz	1000 Hz	2000 Hz	4000 Hz	α_w	Absorption class	NRC
Elegant Render (White) 25 / 25 **	0.10	0.45	0.90	1.00	1.00	1.00	0.75	C	0.85
Elegant Render (White) 40 / 200 *	0.50	0.65	0.85	0.95	1.00	1.00	0.90	A	0.90
Elegant Render (White) 40 / 40 **	0.25	0.75	1.00	1.00	1.00	1.00	1.00	A	0.95

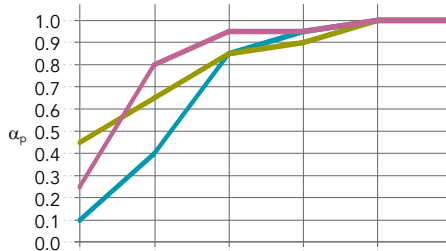

Thickness (mm) / Suspension (incl. tile - mm)

	125 Hz	250 Hz	500 Hz	1000 Hz	2000 Hz	4000 Hz	α_w	Absorption class	NRC
Elegant Render (Colour) 25 / 25 **	0.10	0.40	0.85	0.95	1.00	1.00	0.70	C	0.80
Elegant Render (Colour) 40 / 200 *	0.45	0.65	0.85	0.90	1.00	1.00	0.90	A	0.80
Elegant Render (Colour) 40 / 40 **	0.25	0.80	0.95	0.95	1.00	1.00	1.00	A	0.95



Reaction to fire

A2-s1,d0
B-s1, d0 (Colour)



Fire resistance

Rockfon Mono Acoustic achieves up to 60 min. in accordance with European test standards and national approvals. Please contact Rockfon for fire resistance documentation.



Light reflection and light diffusion

87% light reflection (White)
>99% light diffusion (White)
Colour-dependent (Colour)



Visual appearance

L value: 94.5 (White)
The whiteness (L value) of the product is tested in accordance with ISO 7724 and measured on a scale from 1 (black) to 100 (white).



Humidity and sag resistance

Up to 100% RH.
No visible deflection in high humidity
[Mono Q3 2023 version] Rockfon Mono Acoustic can be used in swimming pools provided it is not exposed to condensation, splashing water or water droplets. The suspension system components must be corrosion resistant and the room and plenum well ventilated. For more information, please contact Rockfon Technical service.



Cleaning

- Vacuum



Hygiene

Stone wool provides no sustenance to microorganisms



Recyclability

Fully recyclable stone wool



Indoor environment

Rockfon ceiling products are classified in Class E1 in accordance with EN 13964 (EN 717-1). Rockfon ceiling products have a very low release of VOCs. A selection of Rockfon products have achieved the following performance levels and labels in indoor air emissions:



Material Health

All materials used in Rockfon products are screened against the technical checklist A20 and the list of substances restricted under REACH and do not contain substances of very high concern (SVHC). Rockfon stone wool fibres comply with safe fibre EU regulation and hold a EUCEB certification.

Rockfon production facilities are certified according to the ISO 9001 and ISO 14001 management systems standards.

Quality and service

Certified Installer Network

In order to deliver the highest quality to our customers, Rockfon has established a Certified Installer Network.

It consists of numerous certified installers who undergo intensive training to ensure high-quality installation of Mono Acoustic:

- Exists in every country where Rockfon Mono Acoustic is present.
- The installers have followed a multiple day training program, including technical knowledge and hands-on experience with the Mono Acoustic system.
- After training, the installers receive a certificate proving successful completion of the training.
- Rockfon Mono Acoustic can only be installed by members of the Certified Installer Network.
- They will stay informed about developments and have access to annual refresher trainings.
- Together with Rockfon, the Certified Installer Network will ensure a seamless installation process for our customers.



Training facilities

Rockfon Mono Acoustic has multiple training facilities across Europe. New and existing installers are trained here to become highly skilled Rockfon Mono Acoustic installers.

The training facilities consist of several rooms, in which a combination of theoretical and practical training takes place. The full installation process is educated by our dedicated Rockfon Mono Acoustic trainers.



On-site support

Rockfon Mono Acoustic technical and sales colleagues have personally completed these comprehensive training courses. Consequently, their expertise in Rockfon Mono Acoustic is extensive, enabling them to offer proactive and excellent on-site support upon request. Whether it's before, during, or after the installation, they are eager to provide assistance. Please visit the Contact page of your local Rockfon website and reach out to us.

Maintenance

Ensuring the longevity of the Rockfon Mono Acoustic surface is essential. The monolithic surface is easy to maintain and refresh, making it a sustainable choice for the future.

Cleaning

Rockfon Mono Acoustic has an anti-static coating, meaning it does not retain dust and can be kept clean. To clean the surface, use a vacuum cleaner with a soft brush operating at low power. The ceilings must not be cleaned with water or wiped with a wet cloth. Minor dirt can be covered using a pencil paint brush. Simply apply Rockfon Mono Acoustic Elegant Render to the bristles of the paint brush and dab it against the panel where there is dirt. More severe dirt has to be covered by respraying a new layer of Rockfon Mono Acoustic Elegant Render.

Refreshment

Rockfon Mono Acoustic ceilings can be renewed or refreshed by applying a new layer of Elegant Render. For this, we advise you to reach out to the certified installer that performed the initial work or another certified Rockfon Mono Acoustic installer.

By applying two extra (thin) layers of Elegant Render, the sound absorption ratio stays almost unaffected and the ceiling surface looks fresh again.

Damages

Any damage to a Rockfon Mono Acoustic surface can always be repaired. The same base materials (Rockfon Mono Acoustic components) that the surface is made of must be used for this purpose.

Superficial damage (screw holes) or minor cracks and scratches can be easily repaired using a small quantity of Elegant Render on the damaged parts. Alternatively, a thin layer of the render may be applied on the full ceiling.

Damage like screw holes, dents, cracks or scratches can be repaired by applying filler/render and sanding down the surrounding surface carefully and applying a small quantity of render on the damaged parts. Alternatively, a thin layer of the render may be applied on the full ceiling.

In the case of larger cracks, significant or structural damage (water damage, heavy impact), replacement of entire panels or fragments is needed. We advise you to reach out to the certified installer that performed the initial work or another certified Rockfon Mono Acoustic installer.

Installation

Installation overview – FE

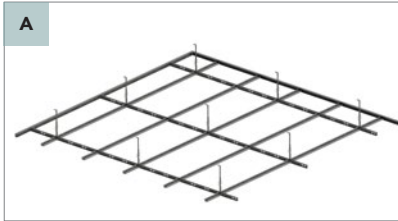

Grid installation (optional):
Install Chicago Metallic™ Monolithic grid.



Panel installation:
Mechanically fix the Rockfon Mono Acoustic panels to the grid. Direct installation (mechanical/adhesive) on airtight substrate is also possible.

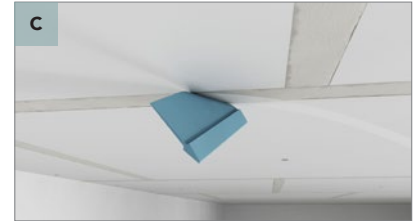

Fill joints, insert tape and finish joints:
Fill the joints properly with preferred tool.

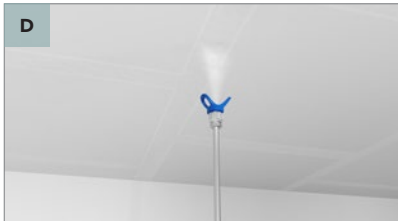

Spray joints only:
Spray one thin layer of render on only the joints in one direction.

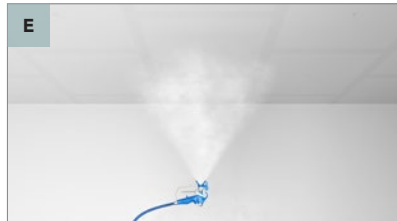

Spray surface:
Directly after spraying the joints, spray one thin layer of render on the full surface (crossing).

After drying, repeat step D & E.
Once dry, jump to step F.



Sand joints:
After sanding with preferred tool, ensure that the joints are perfectly smooth.



Check joints and center of panels.

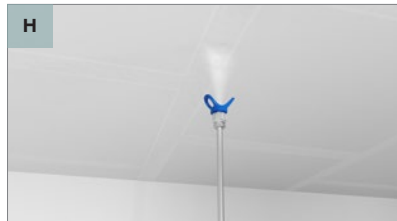

Spray joints only:
Spray one thin layer of render on the joints to achieve same structure as on the surface. Repeat once after one hour.

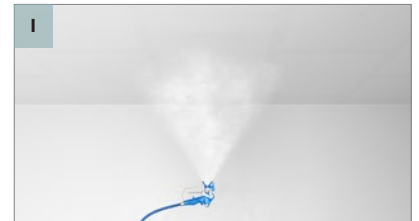

Spray surface:
Finish the surface with a final layer of render.

Installation overview – TE

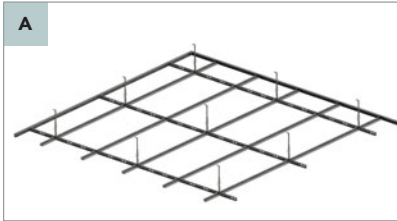

Grid installation (optional):
Install Chicago Metallic™ Monolithic grid.



Panel installation:
Mechanically fix the Rockfon Mono Acoustic panels to the grid. Direct installation (mechanical/adhesive) on airtight substrate is also possible.



Fill joints, insert tape and finish joints:
Use your preferred tool to fill the joint. Repeat until the joint is properly filled.



Sand joints:
Sand the filled joints with your preferred tool to level the panel surface.



Check joints and center of panels.

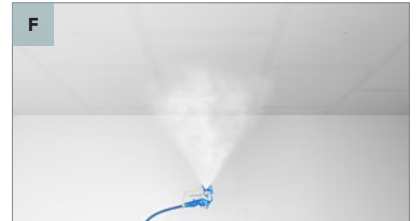

Spray surface (1):
Spray one thin layer of render on the full surface (crossing).

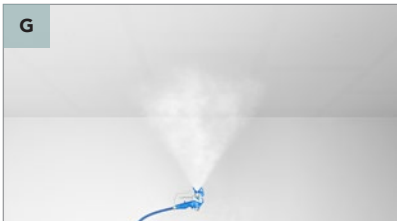

Spray surface (2):
Spray one thin layer of render on the full surface (crossing).

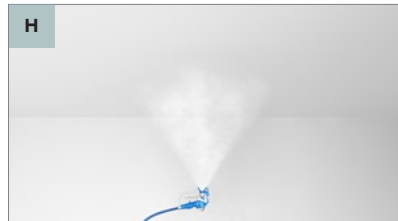

Spray surface (3):
Finish the surface with a thin final layer of render (crossing).

Planning

Detailed planning is essential.

The installation of Rockfon Mono Acoustic is a time-consuming process. It's not the installation itself that requires significant time, but rather the drying times of the wet components (filler and render). Following the recommended drying times is crucial to prevent undesirable outcomes in terms of both aesthetics and functionality.

The activities on the jobsite require careful planning. Activities that produce dust or air pollution should be scheduled and completed before installing Rockfon Mono Acoustic. Any activities generating dust within the room or its surroundings must be avoided during or after the installation.

The controlled mechanical ventilation and heating system can only be turned on when the room is properly clean of dust (this also concerns the test phase of the heating and ventilation system).

The monolithic nature of the system means it is non-demountable. Careful sequencing of the construction work is essential along with the installation of hatches, if access is required.

The installation time of Rockfon Mono Acoustic is heavily dependent on the type of jobsite.

Consumption guide

Dimensions (mm)	1200 x 1200	1800 x 1200
Rockfon Mono Acoustic panels	0,70	0,47
Chicago Metallic Monolithic main runner T35	0,84	0,84
Chicago Metallic Monolithic cross furring channel	1,67	1,67
Chicago Metallic Monolithic C Channel trim	Equal to perimeter of the room	
Perimeter hold down clips	1 piece / cross tee – perimeter trim connection	
Fastening washer (250 pcs/box)*	0,70	0,93
Intersection bracket (150 pcs/box)	4,17	3,71
Rockfon Mono Acoustic Tape (R40/150 m1)	1,67	1,39
Rockfon Mono Acoustic Powder Filler (15 kg/tub)	FE: 0,45 / TE: 0,75	FE: 0,36 / TE: 0,6
Rockfon Mono Acoustic Colour Filler (20 kg/tub)	FE: 0,6 / TE: 1,0	FE: 0,51 / TE: 0,9
Rockfon Mono Acoustic Elegant Render (15 kg/tub)	White 1,0–1,2 kg (wet)	
	Colour 1,5 kg (wet)	
Rockfon SwiftFix	2,2–2,5 kg	Not possible

Consumption is per m².

In critical light conditions higher consumption may be required.

* Excl. perimeter.

Checklist

What to take into account during the design phase of a Rockfon Mono Acoustic project?

During the design and pre-installation phase of Rockfon Mono Acoustic, it is vital to always check room and building conditions. Not checking conditions before installation can lead to undesirable outcomes over time.

Checklist

- It needs to be checked whether the (constructional) ceiling of the room itself – where the grid (if any) will be attached to – is airtight. Air pressure difference in the area in front of and behind the Rockfon Mono Acoustic panels is prohibited, as this can lead to undesirable aesthetics. Especially a lower air pressure in the area behind the Rockfon Mono Acoustic panels (plenum) compared to the air pressure in the room is forbidden.
- If there are any ventilation pipes present, they need to be free from cracks and holes. This is to avoid air pressure differences.
- It needs to be checked that there are no holes between the room and adjacent rooms, because they can cause airflow. This can again lead to air pressure differences.
- The building owner needs to be made aware that obvious sources of air pollution (such as candles, big stoves, open fireplaces or production dust) can lead to undesirable aesthetics over time. It's highly recommended that these are to be avoided or dealt with in the correct way (e.g. ventilation, positioning).
- It's important to note that like all seamless acoustic ceilings, Rockfon Mono Acoustic is not compatible with 'Plenum Suction Ventilation Systems' that draw up large volumes of air from the room into the plenum – creating large pressure differences.
- Before installation it should be ensured the room is not heavily polluted with construction dust and dirt – this is particularly important for the final stages of installation, when the render is applied.
- During installation, room temperature should be between 10–35°C (best result is obtained between 18–20°C) and relative humidity preferably 40–60%, maximum 70%.
- After installation, the building should be maintained at a stable temperature. If the delta in temperature change is too big, we advise to not install Rockfon Mono Acoustic in this area. Reason is that these temperature changes can, over time, lead to undesirable aesthetical outcomes.
- If the ceiling is installed using Diffuse Ventilation, the plenum needs to be (vacuum) cleaned during installation.

Air pressure

A lower air pressure in the area behind the Rockfon Mono Acoustic panels (plenum) compared to the air pressure in the room is prohibited, as this can lead to undesirable aesthetics. Take this phenomena into account in the planning phase of the building or room. A ventilation expert should be consulted.

It is recommended to conduct air pressure measurements early in the installation process (before the usage of wet components) to confirm the absence of air pressure differences.

If it's not possible to avoid air pressure differences, there are several approaches to address this. Here are some options:

How to avoid air pressure differences in the area in front of and behind the Rockfon Mono Acoustic panels?

Ventilation grills

One clear solution is the usage of ventilation grills, which perfectly can be applied in the Rockfon Mono Acoustic panels. A ventilation expert should advise on the correct amount of ventilation grills to avoid pressure difference. During installation, the pressure difference should be measured and monitored by a ventilation expert.

Islands

Another solution is to install Rockfon Mono Acoustic as an island. This means that there is an open perimeter, ensuring the same climate in the entire space – also behind the Rockfon System Mono Acoustic.

Ventilation holes in perimeter

A variant of the island solution is the usage of open perimeter trims (e.g. wall angles with ventilation holes). This ensures that air can flow through, resulting in decreasing air pressure difference.

Note: this option might not be sufficient to (completely) solve air pressure difference. It is mandatory that pressure difference is measured and monitored during installation by a ventilation expert. It might be necessary to combine this option with e.g. ventilation grills.

Close connection to elevator shaft

Is the area behind the Rockfon Mono Acoustic panels in open connection with an elevator shaft? This leads to pressure difference every time the elevator moves. Make sure to close the connection between the elevator shaft and the area behind (plenum) the Rockfon Mono Acoustic panels.

If air pressure differences cannot be avoided, Rockfon strongly advises against the installation of Rockfon Mono Acoustic in this room.

Diffuse ventilation

One unique feature of Rockfon Mono Acoustic is its compatibility with Diffuse Ventilation.

By applying diffuse ventilation, an overpressure (2-5 Pa) is established in the plenum. The air is pressed down through the Rockfon Mono Acoustic panels. This enables evenly distribution of fresh air through the entire surface, all the way to the corners (see illustration below). It results in high air exchange (and thus plenty of fresh air) without draft or noise.

The use of diffuse ventilation also comes with a lower suspension height of Rockfon System Mono Acoustic, increasing ceiling height in a room. As it also eliminates the use of ventilation grills, the aesthetic advantage is huge. As a result of the latter, the acoustic absorption area of the ceiling is bigger.

To apply diffuse ventilation, the plenum should be free of cracks bigger than 1mm. During installation, the plenum should be (vacuum) cleaned. The plenum height should be min. 200mm. The maximum ceiling area with diffuse ventilation is 200m². However, with the use of Rockfon® Soundstop™, compartments are easily made, leading to unlimited possibilities.

Additionally, third party measurements show no change in particles or fibers concentration in the room before and after the use of diffuse ventilation, making it a completely safe solution.

For more information on Diffuse Ventilation, please get in touch with our local Rockfon Technical Service.

The illustration shows two solutions:
- A: Suspended ceiling of 600mm with traditional mechanical ventilation (VAV)
- B: Suspended ceiling of 200 mm with diffuse ventilation (DVAV)

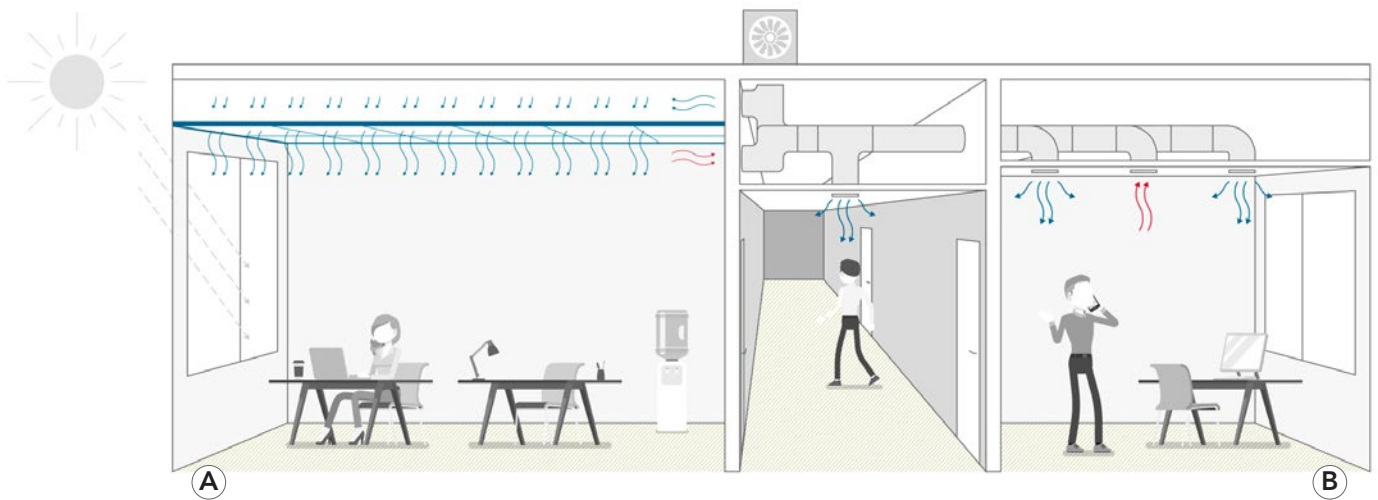

Temperature

What temperature levels are needed during and after installation of Rockfon Mono Acoustic?

During installation, room temperature should be between 10–35°C (best result is obtained between 18–20°C) and relative humidity preferably 40–60%, maximum 70%.

It should be clarified in advance if there will be constant and big temperature changes in the building after installation of Rockfon System Mono Acoustic. If the delta in temperature change is big, we advise to NOT install Rockfon System Mono Acoustic in this area. Reason is that these temperature changes can, over time, lead to undesirable aesthetical outcomes.

It is recommended to maintain a stable temperature in the building after installation.

Humid environments

It is possible to apply Rockfon Mono Acoustic in humid environments. However, installations in humid environments (like swimming halls) require special attention due to a high risk of corrosion.

In swimming halls and other humid environments, the system should be installed as follows:

Checklist

- The grid and suspension system used should be corrosion resistant. This should be either Class D according to EN 13964:2014 (classes of corrosion protection) or C5L according to ISO 12944. Get in touch with Rockfon for advice.
- Ventilation in the swimming hall and the plenum should be optimal to avoid condensation issues. A ventilation expert should be consulted.
- We strongly recommend to not install Rockfon System Mono Acoustic completely against the wall, leaving an opening (Island principle) where air can circulate in the room/plenum. This creates a similar climate (temperature and humidity) in the room and plenum.
- The ceiling should be at a height of at least 5 meters in order to avoid water splashing against the ceiling. Splashing may lead to spots on the Rockfon Mono Acoustic surface. Although these spots can be refreshed (see Maintenance guide), it is better to prevent it from happening.
- If the delta in temperature changes is too big, we advise to NOT install Rockfon System Mono Acoustic in this area (see section about 'Temperature').

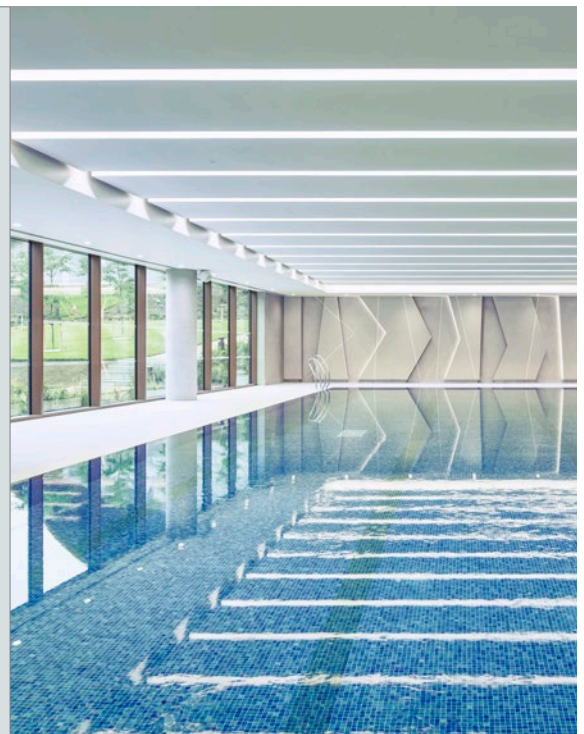

Please reach out to your local Rockfon Technical Service if you are considering installing Rockfon Mono Acoustic in humid environments.

Restrictions

When does Rockfon advice not to install Rockfon Mono Acoustic?

Some spaces or conditions might not be suitable for installation of Rockfon Mono Acoustic. A few examples:

- Spaces where air pressure differences can't be avoided or solved (e.g. due to leaks/cracks or Plenum Suction Ventilation). This can potentially lead to undesirable aesthetical outcomes.
- Surfaces that are subject to very critical light conditions. This applies to all monolithic surfaces, meaning that very critical light conditions can expose the tiniest irregularity on the surface. As it is manual work, this needs to be taken into account.
- If there are constant and big temperature changes in the building. This could lead to undesirable aesthetical outcomes.
- In swimming pools or other humid environments where no corrosion resistant grid is used, it is prohibited to install Rockfon Mono Acoustic.
- In swimming pools or other humid environments with a high chance of water splashing against the surface, such as rooms with insufficient height.
- When there is no grid behind every joint of the Rockfon Mono Acoustic panels. This means that double layer grid structures like CD-constructions are strongly discouraged.
- It's prohibited to install Rockfon Mono Acoustic in outside environments.

If Rockfon's advice is negative and/or the above is not respected, Rockfon cannot be held accountable for the outcome.

Technical drawings

A library of technical drawings (details, transitions, integrations & islands) of Rockfon Mono Acoustic is created based on the many years of experience with the product in the market.

Here we showcase the most common drawings, all available in PDF and DWG-format. For any specific details or questions, please reach out to our local Rockfon Technical department.

Standard solution (A-A)

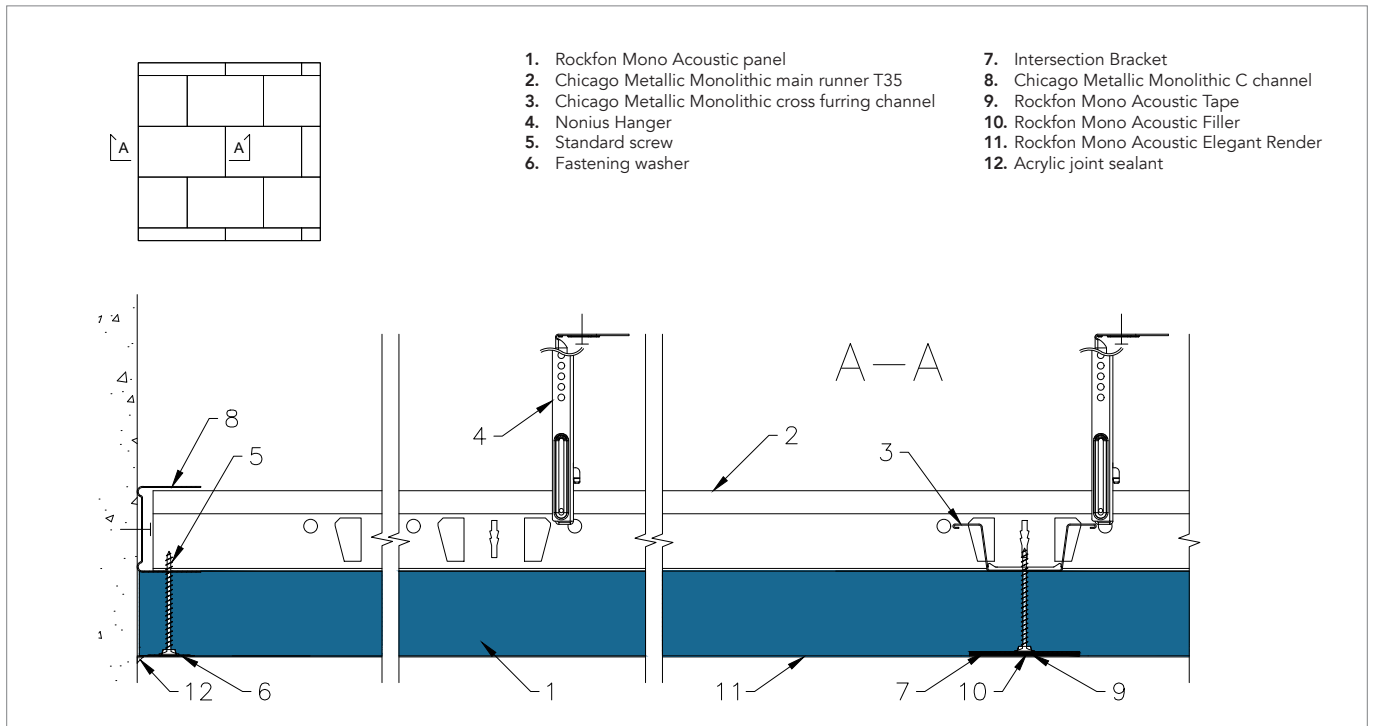

Standard solution (B-B)

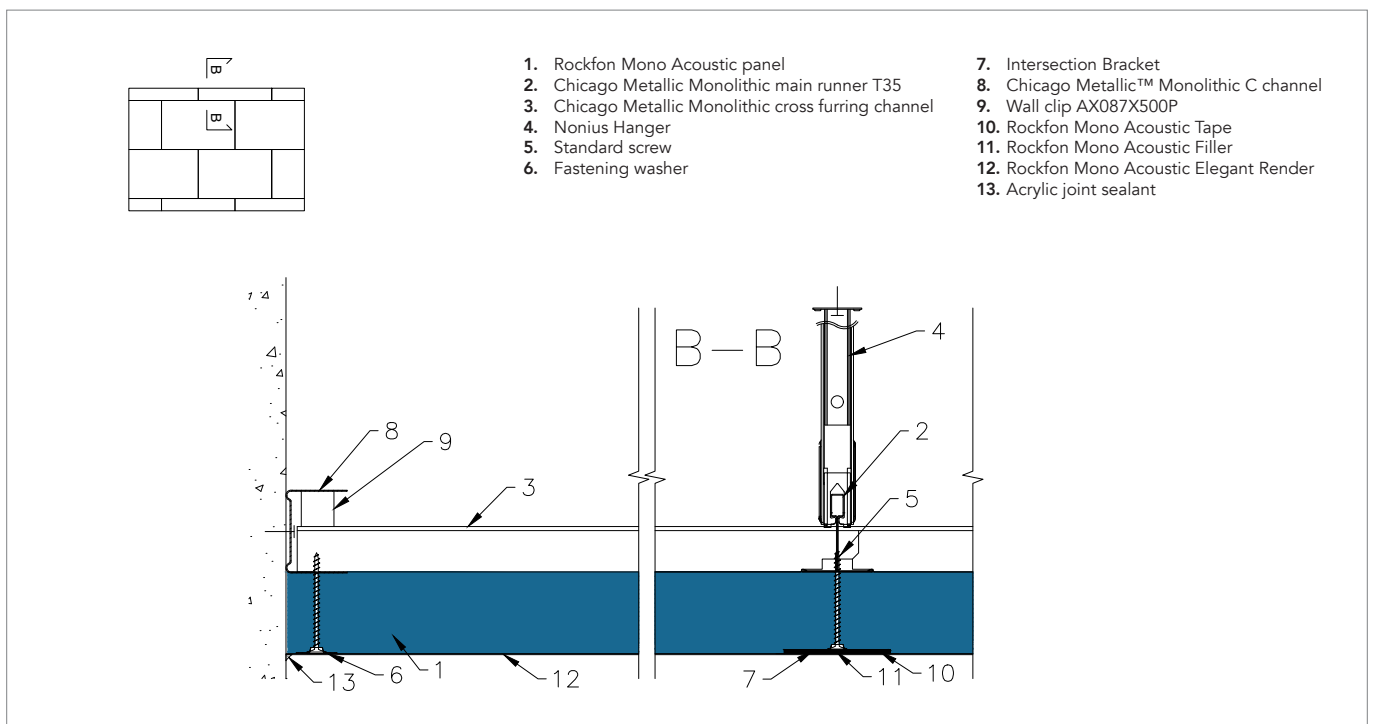

Floating perimeter

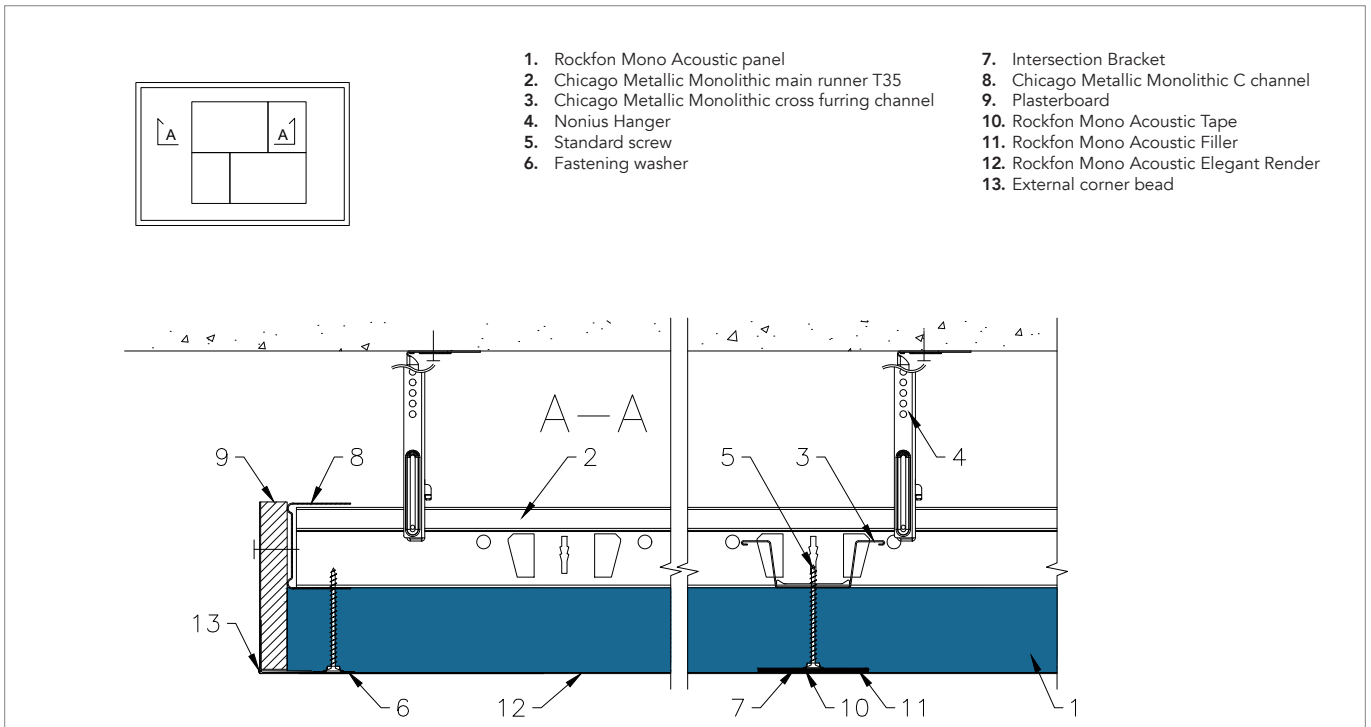

Shadow trim – plasterboard

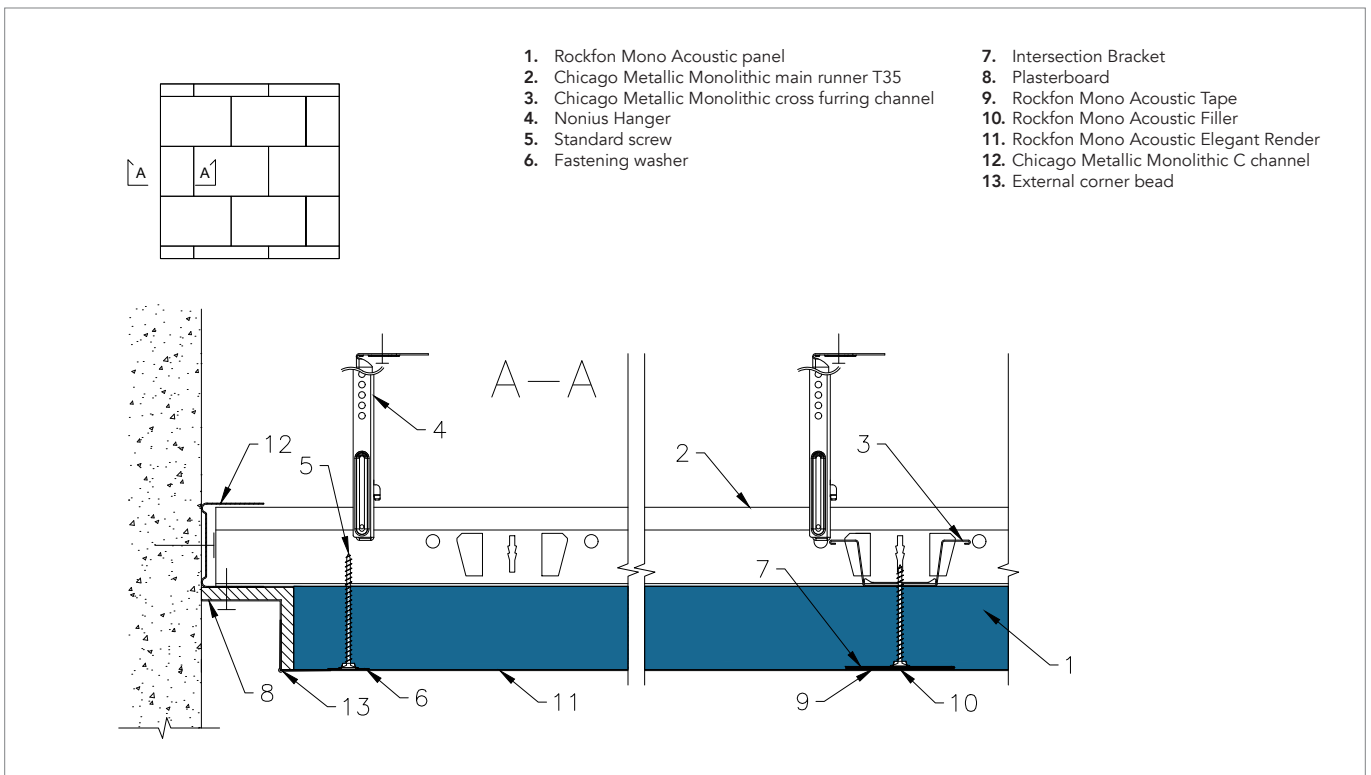

Transition solution – plasterboard

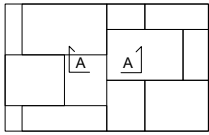

- | | |
|--|---|
| 1. Rockfon Mono Acoustic panel | 6. Fastening washer |
| 2. Chicago Metallic Monolithic main runner T35 | 7. Rockfon Mono Acoustic Filler |
| 3. Chicago Metallic Monolithic cross furring channel | 8. Rockfon Mono Acoustic Tape |
| 4. Nonius Hanger | 9. Rockfon Mono Acoustic Elegant Render |
| 5. Standard screw | 10. Plasterboard (12.5mm) |
| | 11. Plasterboard (15mm) |

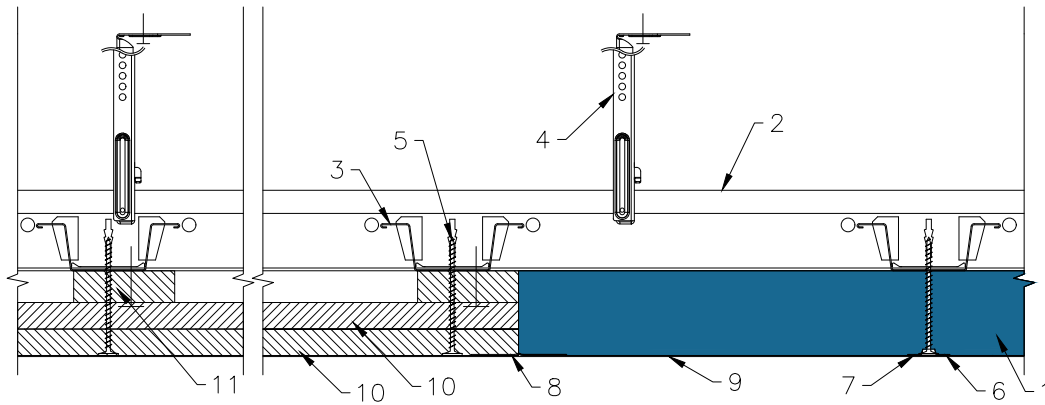

Internal corner

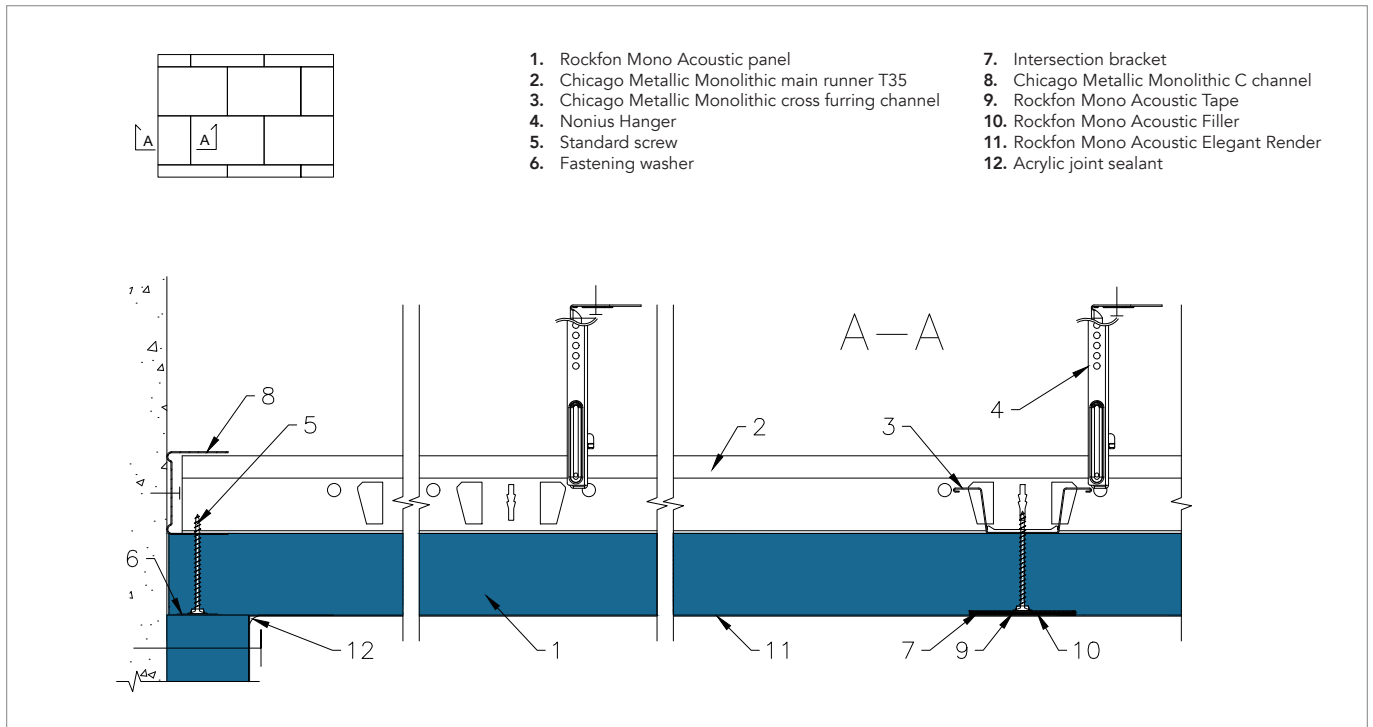

External corner

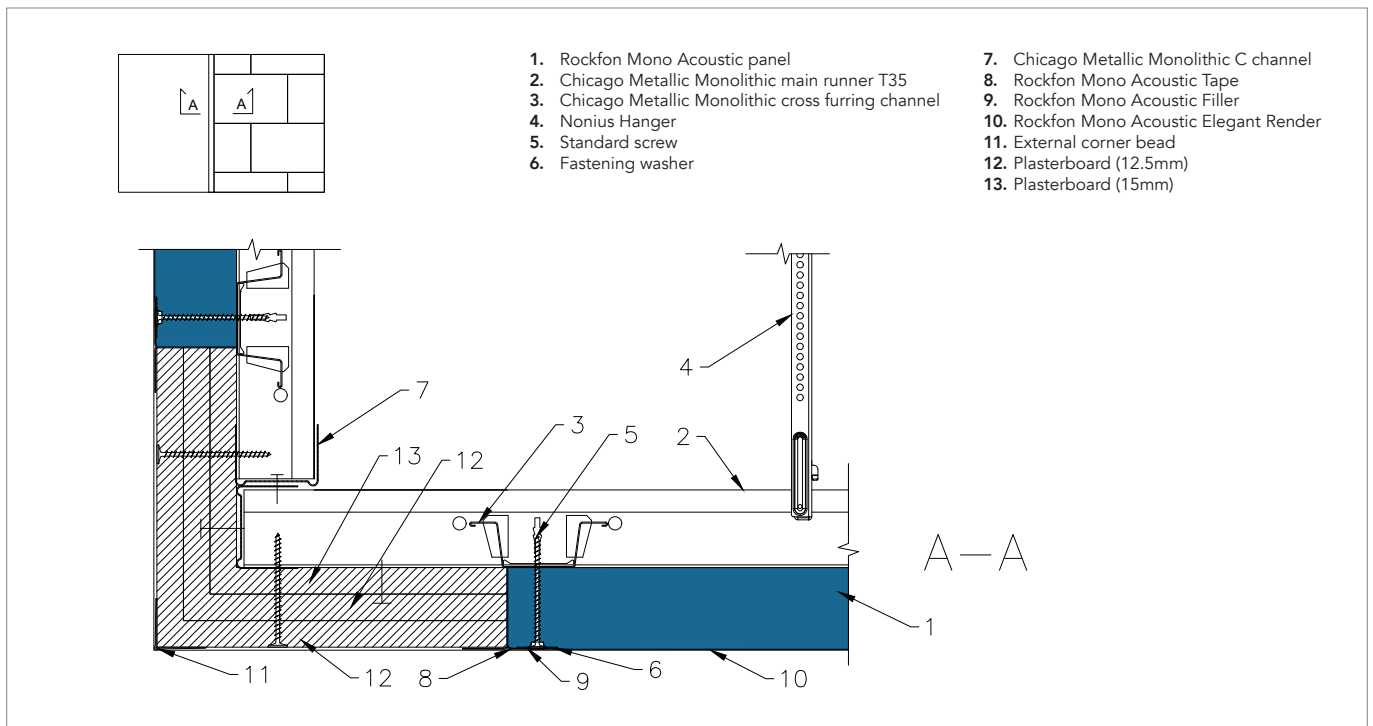

Spotlight integration

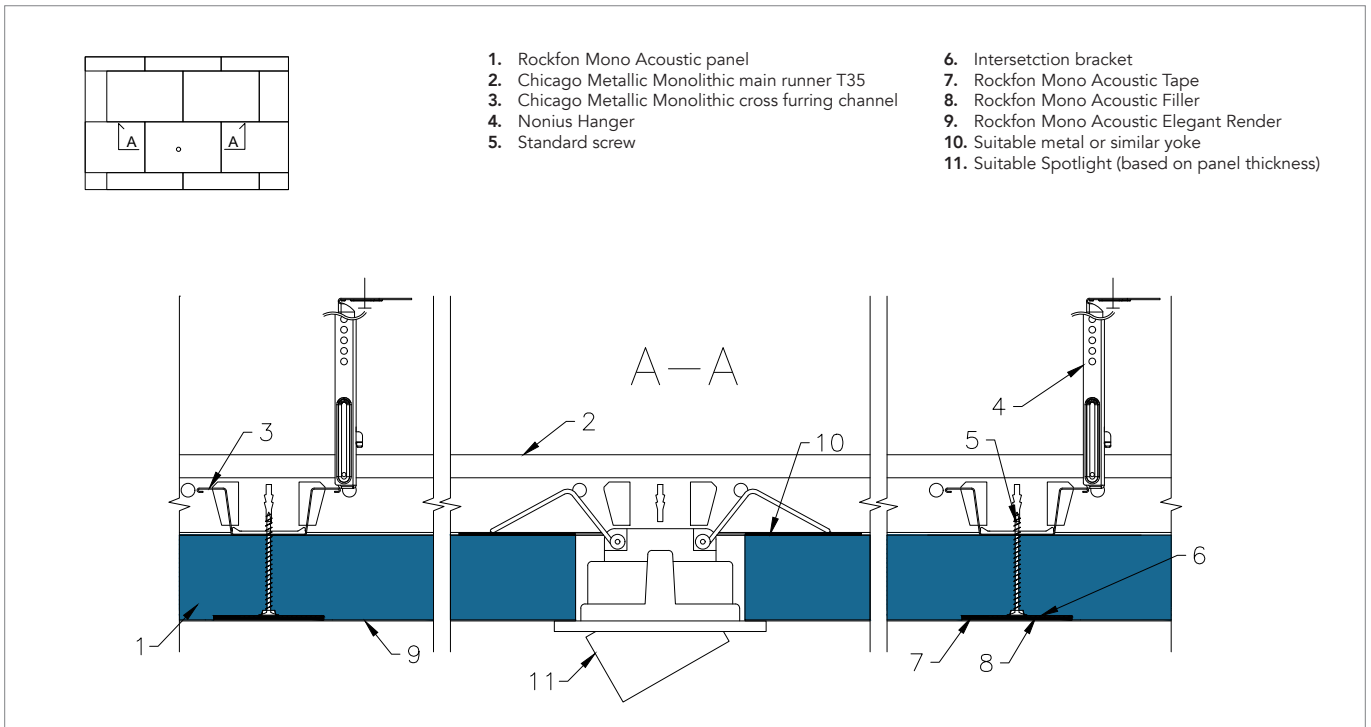

Suspension of elements

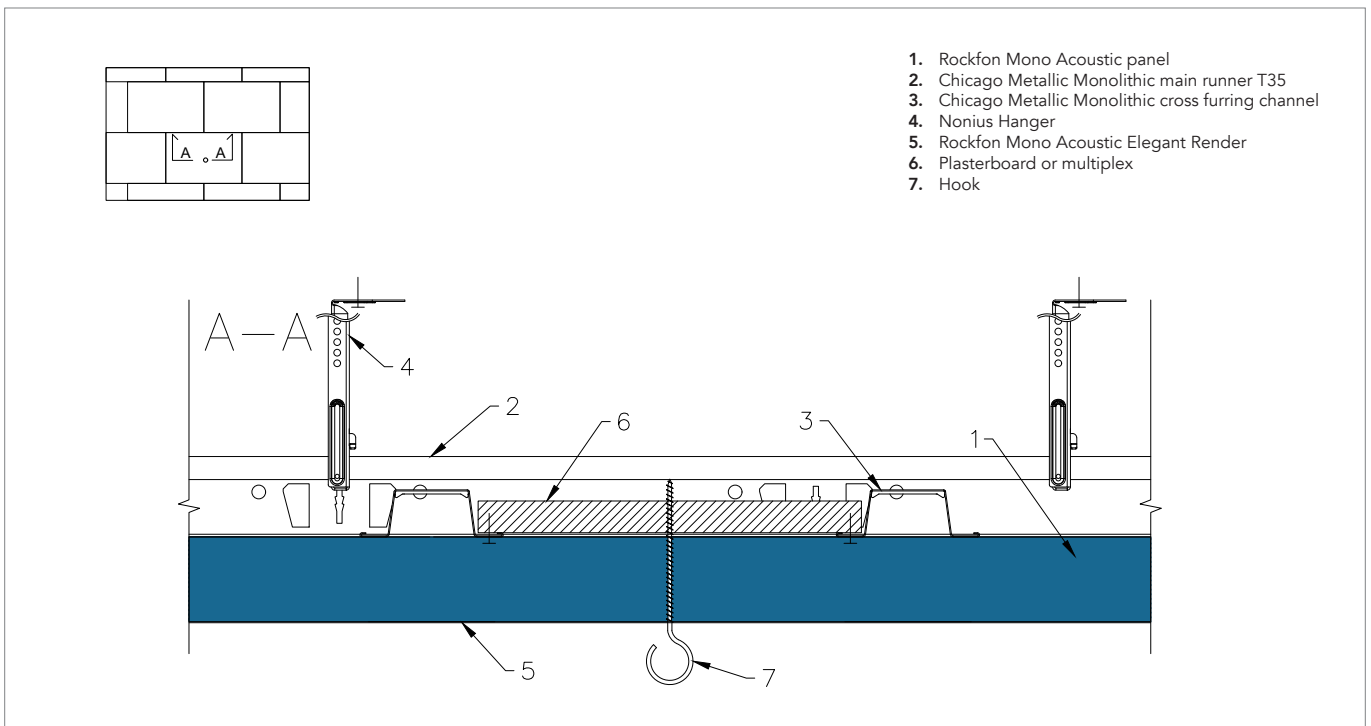

Square inspection hatch

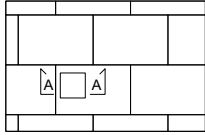

- | | |
|--|--|
| 1. Rockfon Mono Acoustic panel | 7. Intersection Bracket |
| 2. Chicago Metallic Monolithic main runner T35 | 8. Rockfon Mono Acoustic Tape |
| 3. Chicago Metallic Monolithic cross furring channel | 9. Rockfon Mono Acoustic Filler |
| 4. Nonius Hanger | 10. Rockfon Mono Acoustic Elegant Render |
| 5. Standard screw | 11. Mono Acoustic inspection hatch 600x600mm |
| 6. Fastening washer | 12. Acrylic joint sealant |

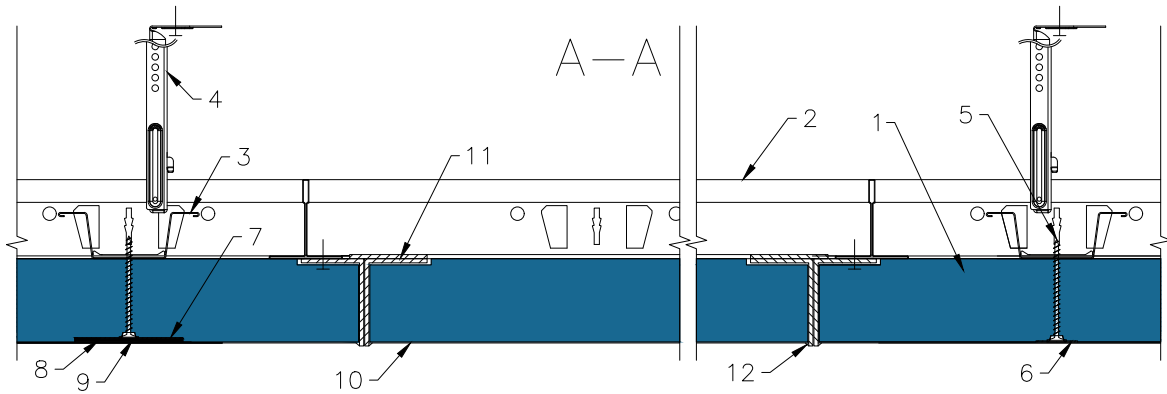

Round inspection hatch

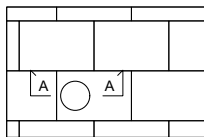

- | | |
|--|---|
| 1. Rockfon Mono Acoustic panel | 6. Fastening washer |
| 2. Chicago Metallic Monolithic main runner T35 | 7. Intersection Bracket |
| 3. Chicago Metallic Monolithic cross furring channel | 8. Rockfon Mono Acoustic Tape |
| 4. Nonius Hanger | 9. Rockfon Mono Acoustic Filler |
| 5. Standard screw | 10. Rockfon Mono Acoustic Elegant Render |
| | 11. Mono Acoustic inspection hatch Ø700mm |

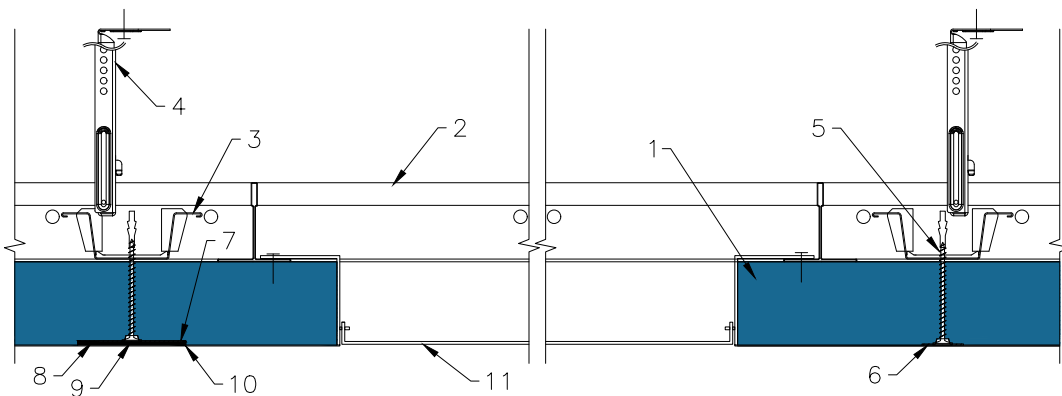

Upstand junction

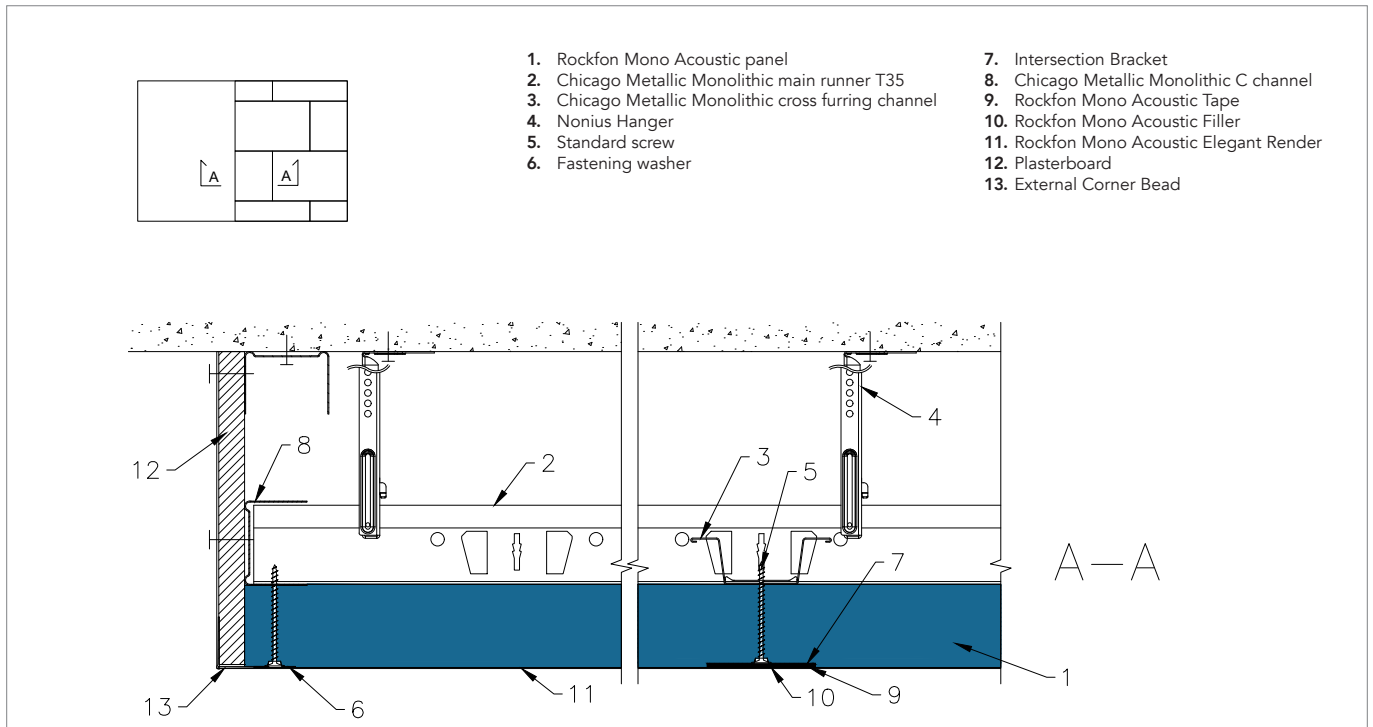

Transition solution – plasterboard (wall)

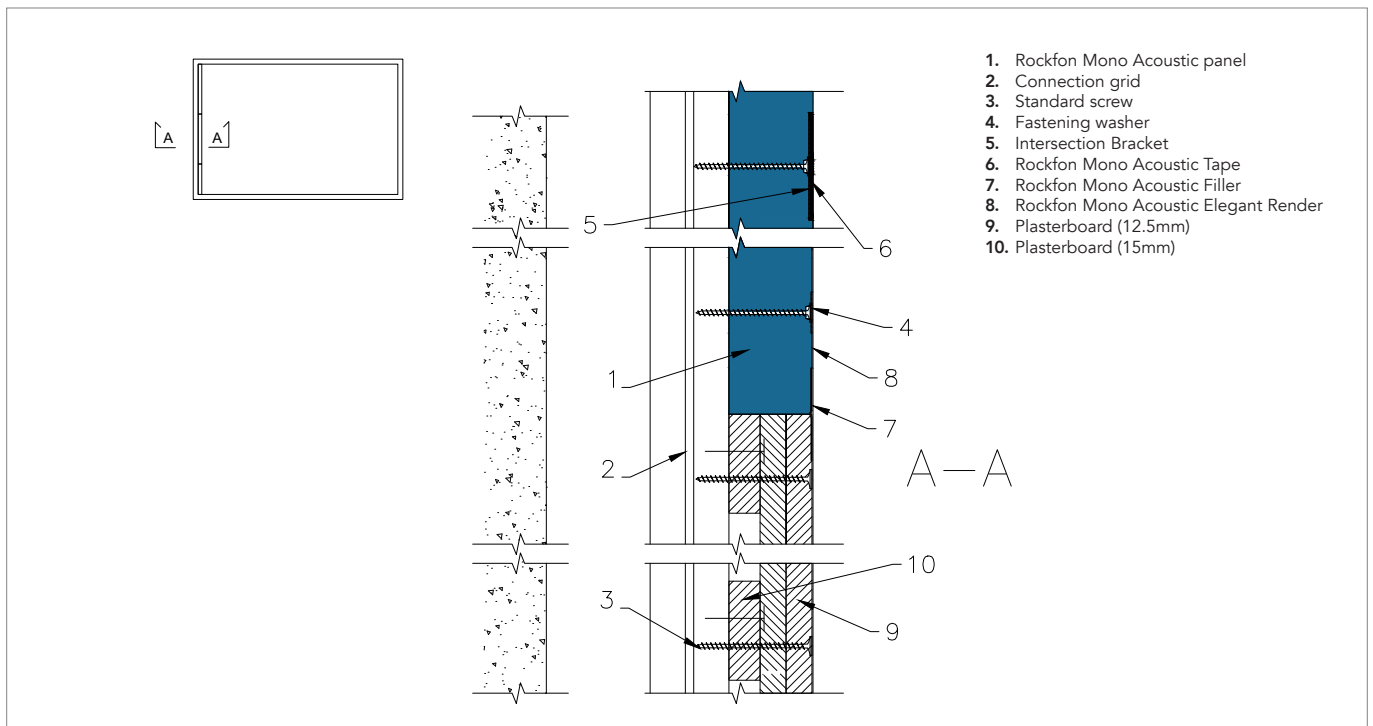

Sounds Beautiful

